

PSOne: **PSTwo:** **PSFour:** **PSRev:**

TTX began development of the Power Shield concept in 1993 in response to the need of the pre DCC Command Control System like Onboard & Dynatrol. The design was modified to work with DCC and has been continually improved to make Power Shield the leader in DCC power protection & regulation. Accordingly, the new Power Shields have three new exclusive features: Overvoltage protection, EZ Programming jumpers **and now Turnout control for the PSRev**. Power Shield was designed by Larry Maier and is manufactured by NCE Corp. to TTX specifications.

Tony's Power Shield Breakers: **PSOne** controls **One** power district, **PSTwo** controls **Two** power districts and **PSFour** controls **Four** power districts all provide over-current and **exclusive over voltage protection**, which sectionalizes the connected track area and prevents shutting down other parts of your layout when the track is shorted.

Tony's Power Shield Reverser (PSRev) unit provides auto-reversing for return loops, reversing Y's and turntables. In addition, it provides the same short circuit protection as **PS'S**

For simplicity, the layout shown has only two mainline track sections, Section 1 and Section 2. Many layouts have more than two mainline (non-reversing) track sections, each of which would be protected with a breaker. These breakers prevent shutdown of the other parts of the layout when a short occurs within one section. Note that between adjacent mainline sections, DCC1 and DCC2 must be kept on the same rail, to prevent shorting the DCC power unit (and tripping the breakers) as the train passes from one section to the next.

The layout shown also has only two reversing sections. A large layout might have more, and reversers can be added as needed. Note that the reverser provides the breaker function (to isolate faults) within its track section, as well as track reversal.

So on this example layout, a fault on any section of the layout would be isolated from all other sections. Track reversal is provided as traffic moves around the two reverse loops. All this is provided from a simple DCC power unit (needs no built-in reverse function).

The Intelligent Breaker and Reverser are solid-state, including power switching, for silent, reliable operation and long life. Both provide on-board LED indication of trip (and indication of track reversal in the case of the reverser), with provision for remote LED indication as well.

If you are skeptical, here is why you should use Power Shield™:

- **Enjoyable Uninterrupted Operating:** Power Shield™ keeps the layout up and running for those operators who can stay on the track.
- **Locomotive or System Protection:** Power Shield™ eliminates the violent voltage and current spikes caused by hard shorts that can melt equipment.
- **Track Power On/Off:** Power Shield can be used to manually switch track power.
- **Fault Isolators:** When Power Shield™ trips, you know where the problem is.
- **Booster Protection:** Although these units have built in protection, the protection circuitry may eventually fail.

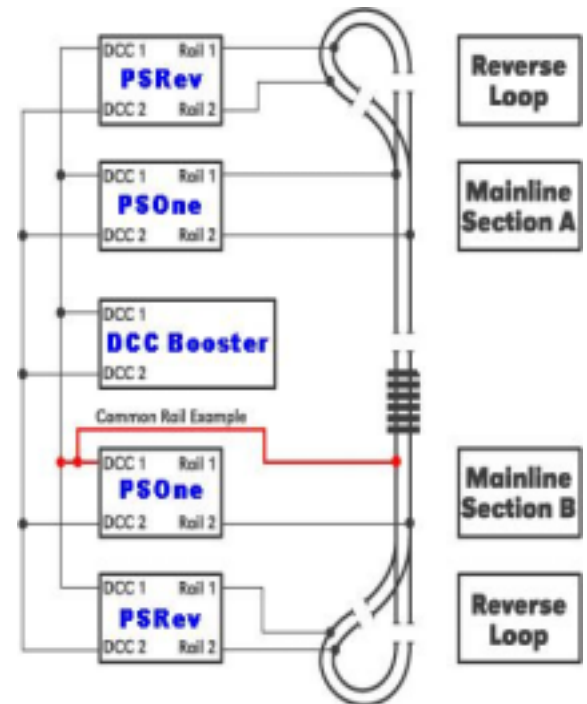

Why Power Shield's are the best DCC Circuit Breakers and Reversers ?

- 8 Amp, All Scales,
- Automatic/Manual Reset.
- Works with Reverse Blocks.
- Over Voltage Protection
- Easy Mount Design at District
- On / Off Reverse, Status Lights
- Multiple Input / Outputs
- EZ Programming Jumpers
- Solid State No Relays

User Guidelines: Page 2

Power Shields are designed so all input/output connections and jumpers can be soldered directly to the appropriate holes on the circuit board. The holes can accept up to 16 AWG wire. If you are using heavier buss wire, then solder a short length of 16 AWG wire to the board and solder-splice this to your heavier buss wire.

If your Power Sections and Reverse blocks are greater than 10 Ft. long be sure to have at least 2 sets of track feeders for that section. Insufficient feeders will cause a voltage drop.

When setting up gaps for reverse sections, we recommended that the gaps be staggered about 1/8 ". Perfectly aligned gaps may reduce the current needed for **PSRev** to reverse properly.

Note that one end of the reverse section will be aligned with normal polarity track power while the opposite or other end will have a polarity mis-match and require the reverser to act.

Test your **PSRev** installation prior to running a train as follows.

Observe that your DCC booster is not being shorted during the tests:

Use a suitable metal object to separately short each of the four gaps that form the reverse section and observe the LED on the **PSRev**.

Shorting the two rail gaps where the polarity is aligned will produce NO LED Indication from the **PSRev**.

Shorting either rail gap where the polarity is mismatched will cause the LED to rapidly flash. You can also short both rails in the reverse section and the LED will stay on until short is removed.

If you are using Power Shield Circuit Breakers and Power Shield Reversers together on a layout, and locomotives hesitate when crossing a reverse gap, then increase the **Trip Current** in combination with the **Response Time** on the **PSOne**, **PSTwo** or **PSFour** to the next level or until the **PSRev** operates correctly

Connections for PSOne and PSRev

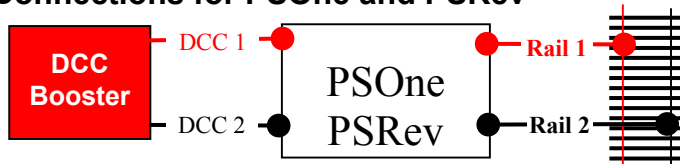

Connections for PSTwo

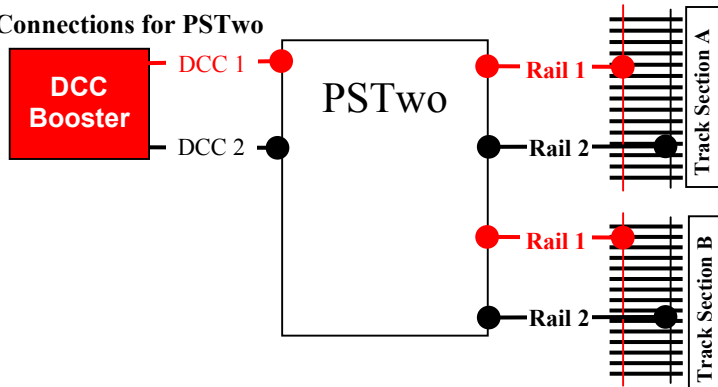

Quick Start

All connections involve two inputs from the DCC booster, or the main line track buss and two outputs to the isolated track section or reverse block.

PSOne, PSTwo, PSFour & PSRev come ready to operate without utilizing the programmable options described on page 3 & 4.

Tony's Train Xchange Pinewood Plaza 57 River Rd. Box 1023, Essex Jct., VT. 05452
Toll Free: 800-978-3472 Fax: 802-878-5550 e-mail: info@tonystrains.com Web: www.tonystrains.com

We Offer and Support More DCC Products Than Anyone!

PSOne: Installation & Operation Information

PS One comes ready to operate on most layouts without utilizing the programmable options described below. **Page 3**

No external power supply is required.

Connection: (Input Max 24 volts DCC) Please review *User Guidelines* (opposite page) before installation. REV 11-25-02

Input: Connect DCC power to "DCC1" and "DCC2" inputs (see below). Input /Output polarity must be the same for all PS circuit breakers.

Output: Connect the "RAIL 1" and "RAIL 2" outputs to the isolated track section. Input/ Output polarity must be the same

No "RAIL 1" output is needed for Common Rail applications.

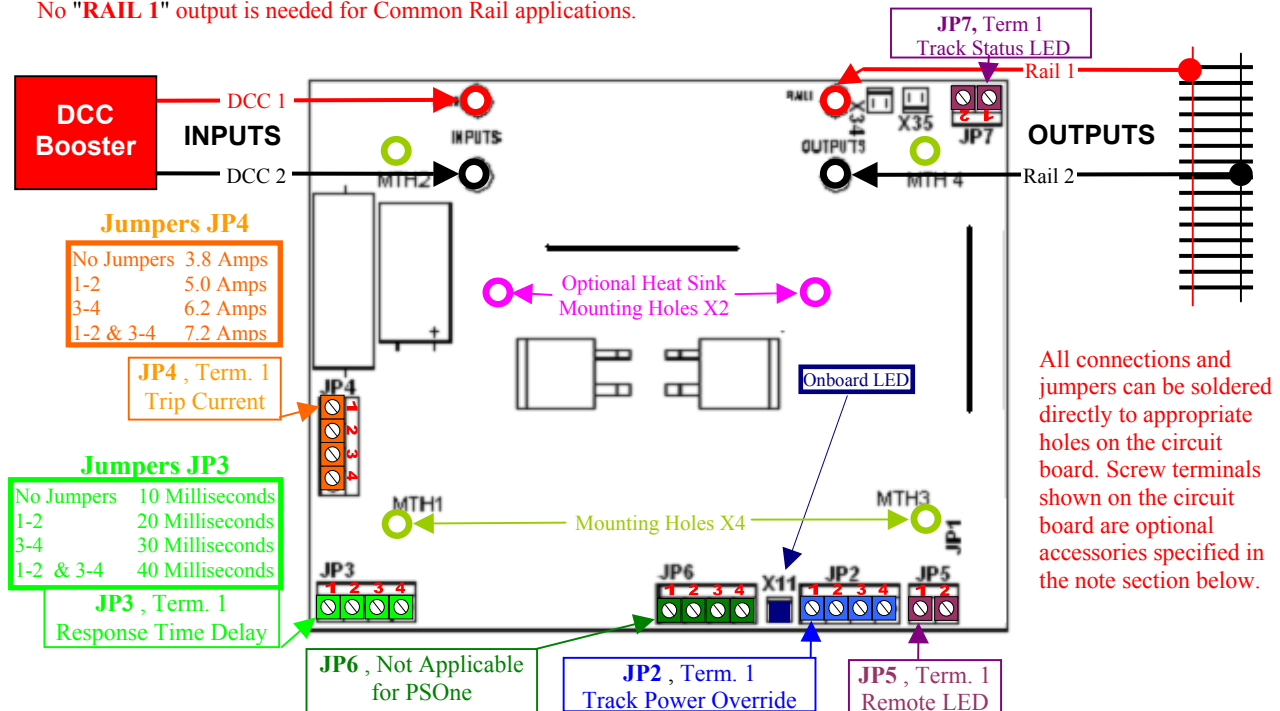

JP4 (Trip Current)

Sets the trip current for the (PS One) breaker functions. See programmable trip current jumper settings in tables above.

JP2 (Track Power Override or Manual Reset)

Terminals 1 and 2 on JP2 control track power. Connect 1-2 to turn OFF track power, while an open circuit from 1-2 turns on track power.

Terminals 3 and 4 are auto/manual reset. An open circuit from 3-4 allows the breaker to function automatically turning track power ON after a fault is corrected. Connecting 3-4 will cause the breaker function to require a manual reset. Once the breaker has tripped, track power will not turn ON after the fault is corrected until terminals 3-4 are open circuit again. If the section powered by the Power Shield contains over 15 sound systems or stationary decoders, or if the section has a large number of incandescent lamps (passenger cars, etc.), then the manual reset may be required to allow a clean turn on after a fault is corrected.

JP3 (Response Time)

JP3 sets the time delay between the occurrence of a fault and the initiation of the breaker function. Certain loads such as incandescent lamps, stationary decoders, and sound systems have a high inrush current when turned on. The breaker waits the programmed delay before turning OFF track power. The time delay allows the breaker function to discriminate between fault conditions and high inrush current track loads. Most layouts can use the 10 millisecond setting without problems. Increase the delay if you have trouble turning ON a particular track section. Some boosters have a relatively fast response time. If your booster shuts down before the breaker trips during a short circuit, then use the shortest (10 ms) time delay. See programmable time delay jumper settings in table above.

JP5 & JP7 (Remote LEDs)

JP5 is for connecting a remote LED to display the operating status of the Power Shield. Terminal 2 connects to the anode and terminal 1 connects to the cathode (arrow points from 2 to 1). The remote LED operates in parallel with the LED on the circuit board.

JP7 is for connecting a remote LED to display that there is output power to track.

Status: (Onboard LED Indicators)

(X11 LED) PSONE Breaker tripped or track power off: - LED on

Notes

Power Shield's are rated for up to 8 amps operating current. If your layout requires operation above 6 amps continuous current for longer than 10 minutes, then contact Tony's for the optional heat sink package. Optional items with Digikey part numbers are; Four Position Term Block, ED1503-ND, or Two Position , ED1501-ND. Terminal blocks may be used to provide screw in connections for JP (solder- in) jumpers specified above.

Tony's Train Xchange Pinewood Plaza 57 River Rd. Box 1023, Essex Jct., VT. 05452

Toll Free: 800-978-3472 Fax: 802-878-5550 e-mail: info@tonystrains.com Web: www.tonystrains.com

We Offer and Support More DCC Products Than Anyone!

PSTwo & PSFour: Installation & Operation Info

PS Two & Four come ready to operate on most layouts without utilizing the programmable options described below. **Page 4**
PSFour is 2, PSTwo panels side by side and can accommodate single or dual inputs.
Please review *User Guidelines* (page 2) before installation. No external power supply is required.

Connection: (Input Max 24 v) Input / Output polarity **must be the same** for PSTwo & Four circuit breakers.

Inputs: **PSTwo**, Connect DCC power to inputs **DCC1, DCC2** or **DCC1A, DCC2A** or **DCC1B, DCC2B** (see below).

Note: The pair DCC1A and DCC2A or DCC1B and DCC2B are parallel, or the same connection as DCC1 and DCC2 and are provided to jumper inputs.

PSFour, Single input Connect DCC power to **DCC1** and **DCC2** inputs, and install jumpers from DCC1 to DCC1A and DCC2 to DCC2A **DCC1A & 2A** between **DCC1B & 2B** (see below). **PSFour**, Dual input, Connect the same as **PSTwo**

Outputs: **PSTwo**, Connect the **RAIL1A** and **RAIL2A** outputs to the 1st isolated track section and

RAIL1B and **RAIL2B** outputs to the 2nd isolated track section

PSFour, Connect the same as **PSTwo** for 4 isolated track sections. **Common Rail applications**. No **RAIL1** output connection is needed.

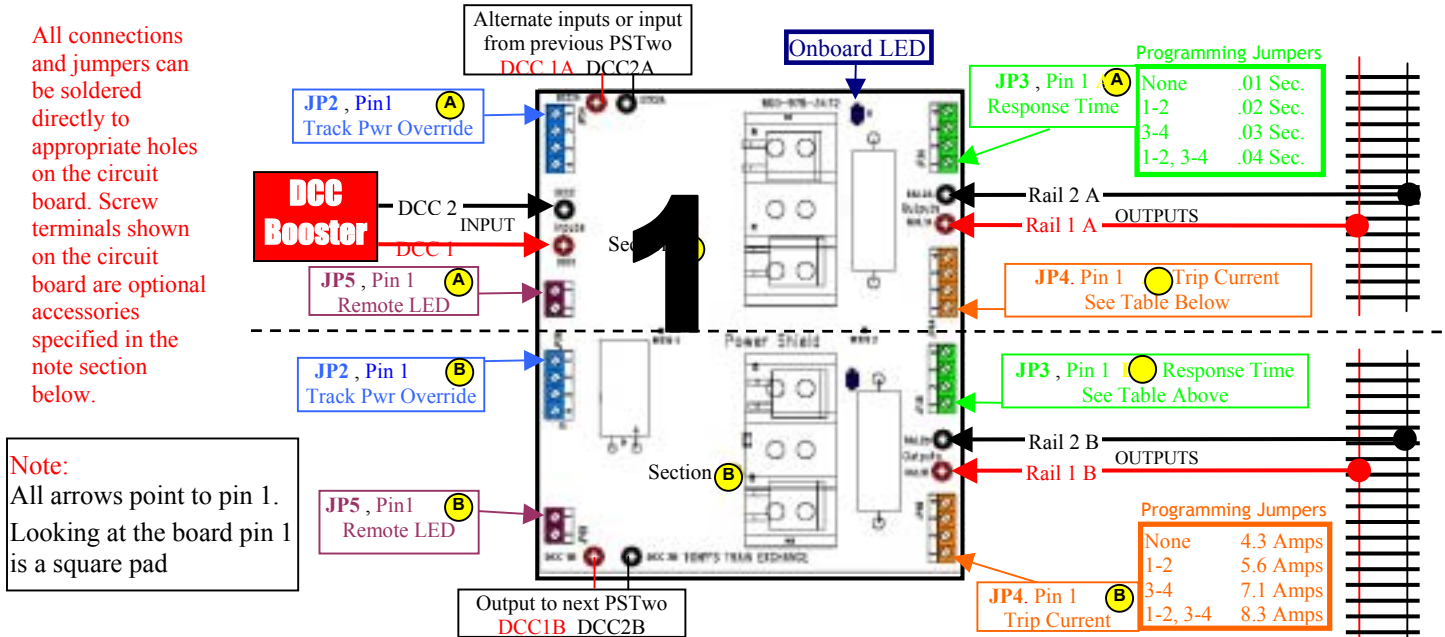

JP4 (Trip Current) Note: section A or B can be set for different values

JP4 Sets the trip current for each output of the PSTwo and PSFour breakers. See **programmable jumper settings in tables above**.

JP2 (Track Power Override or Manual Reset)

JP2 Terminals 1 and 2 control track power. Connect 1-2 to turn OFF track power, while an open circuit from 1-2 turns on track power.

Terminals 3 and 4 are auto/manual reset. An open circuit from 3-4 allows the breaker to function automatically turning track power ON after a fault is corrected. Connecting 3-4 will cause the breaker function to require a manual reset. Once the breaker has tripped, track power will not turn ON after the fault is corrected until terminals 3-4 are open circuit again. **If the section powered by the Power Shield contains over 15 sound systems or stationary decoders, or if the section has a large number of incandescent lamps (passenger cars, etc.), then the manual reset feature may be required to allow a clean turn on after a fault is corrected.**

JP3 (Response Time) Note: section A or B can be set for different values

JP3 sets the time delay between the occurrence of a fault and the initiation of the breaker function for each output. Certain loads such as incandescent lamps, stationary decoders, and sound systems have a high inrush current when turned on. The breaker waits the programmed delay before turning OFF track power. The time delay allows the breaker function to discriminate between fault conditions and high inrush current track loads. Most layouts can use the 10 millisecond setting without problems. Increase the delay if you have trouble turning ON a particular track section. Some boosters have a relatively fast response time. If your booster shuts down before the breaker trips during a short circuit, then use the shortest (10 ms) time delay. See **programmable jumper settings in table above**.

JP5 (Remote LED) no resistor required

JP5 is for connecting a remote LED to display the operating status of each output of PSTwo and PSFour. Terminal 2 connects to the anode and terminal 1 connects to the cathode (arrow points from 2 to 1). The remote LED operates in parallel with the circuit board LED.

Status LED Indicators

PSTwo & PSFour Breaker tripped or track power off : **LED** on

Notes Power Shield's are rated for up to 8 amps operating current. If your layout requires operation above 6 amps continuous current for longer than 10 minutes, then contact Tony's for the optional heat sink package. Optional items with Digkey part numbers are; Four Position Term Block, ED1503-ND, or Two Position, ED1501-ND. Terminal blocks may be used to provide screw in connections for JP (solder- in) jumpers specified above.

Tony's Train Xchange Pinewood Plaza 57 River Rd. Box 1023, Essex Jct., VT. 05452

Toll Free: 800-978-3472 Fax: 802-878-5550 e-mail: info@tonystrains.com Web: www.tonystrains.com

We Offer and Support More DCC Products Than Anyone