



Navigating the Stationary Decoder and Switch Machine Jungle



by Don Fiehmman

Don Fiehman drafted this handy guide as a quick reference resource for users.

If you are going to install new switch machine or convert old machine to DCC there are many decisions to make. Which decoders matches up with the switch machine, is extra power needed. How can a short circuit on the rails be prevented from cutting off the power to the stationary decoder. How do you number switches and address the decoder. Hopefully this guide will answer most of those questions.

More and more modelers are converting layouts from dc to DCC operation. DCC not only lets you running locomotives using mobile decoders, but you can also control switch machines with accessory or stationary decoders. If you are building a new layout the popular choice of switch machines is the Tortoise. There are a number of good choices for stationary decoders for the Tortoise like the Hare™ or the Switch-It. The Hare/Tortoise is a good choice when retrofitting or adding new switch machines. The Hare is a new second generation line of intelligent stationary decoders that can align a turnout and prevent short circuits. The Hare can sense that a switch is set the wrong way correct it before a short occurs. The Hare has programable speed, route setup and a new lock out feature.

It is not always possible to replace switch machines. Many times they are in a location that is not easy to replace. Over time machines get buried in the scenery, or in a location that is almost impossible to reach. This is what I was faced with as I started to convert my layout from a Dispatchers Panel with all the switch controls in one location to DCC control. The advantage of DCC control is the train operator can control turnouts with a handheld cab instead of having to have to request the dispatcher to throw the switch or, when alone having to run back and fourth playing the part of an engineer and the dispatcher. You could still have a dispatcher with DCC that controls the layout with a PC or using another handheld cab. Many layouts are installing computers to control switch machines.

One of the changes in operation with DCC is you can follow your train and not be stuck in one place with a stationary throttle. In order to convert the switch machines on my layout a plan of attach was needed. I first decided that mainline switches would be DCC controlled and switches off the mainline that were easily reached would have manual control. With the number of switches to convert my conversion took place over a long period of time.

My first conversion was a double slip that also was the throat of a reversing loop. This was easy to reach and Tortoise switch machines were use with an NCE Switch-it. Stationary decoders use an address range that is different from the mobile decoders. In this case I simply used default addresses 1 and 2. To further automate the reversing loop I used the PS-REV that has an output to control that can control the switch at the throat of the loop. This allows a train to go thru the loop have the switch align automatically then and exit the loop. When the Hare™ became available it was an inspiration to convert more switches to DCC control. The Hare/Tortoise was used at the end of a passing siding the seems to get left set the wrong way. With the Hare when an engine approaches the misaligned turnout the Hare senses it and corrects the switch

position. As I got to looking at the rest of the layout I realized that many of the switch machines were going to be very difficult to replace. It would be much easier to leave them in place and find a matching stationary decoder.

Types of Stationary Decoders

Stationary decoders are normally mounted under the layout so size is not a problem. Stationary decoders can have from 1 to 8 outputs depending on the model. Some stationary decoders were designed to operate both switch machines and signal lights. These required programing to define the function of each output. Unlike a mobile decoder that only has two wires to connect to a motor that runs two directions at variable speeds, stationary decoders need to handle a variety of types of power output. There are two basic type of switch machine power and a subcategory in each. First is the older twin coil or solenoid type machine. The second is the motor driven switch machine. In the twin coil category there are the high current machines and then the medium to low current types. For motor types of machines we have the stall type machine and then the motor type that cut off the power when the they reach the end of travel. The stationary decoders vary in the type of machine that they work with the best. Some of the newer stationary decoders are designed to drive one style switch machine.

Here is a list of the switch machines and their types. This chart is by no way complete. There are many more I'm sure. It is broken down into 2 major categories and 2 subcategories for each. These categories will be used later to match up with the preferred stationary decoders.

Motor Driven		Twin Coil	
Stall Type (Type A1)	Power Cut Off Type (Type A2)	Low to Medium Current (Type B1)	High Current (Type B2)
Tortoise SwitchMaster	PFM/Fulgerex, Scale Shops (Note 1)	Atlas Peco	Rix NJI Tenshodo

Note 1: Needs series lamp or resistor to reduce voltage.

Some stationary decoders are designed to either drive a particular type of switch machine, some are programable and can match many types of machines. The power for the decoders to operate the switch machines can be either from the DCC signal/power feed to the decoder or from a separate power source. With some stationary decoders the choice of the power source is optional.

Motor driven machine need low power. Stall type machines need a constant power. The twin-coil machines are the opposite and need high power for a very short time. To provide the higher power many decoders include a capacitor discharge unit for the source of power. Wiring for motor type machines use either two or three wires. The twin-coil normally use three wires. The two positions of a switch are called different names. I prefer Normal and Reverse.

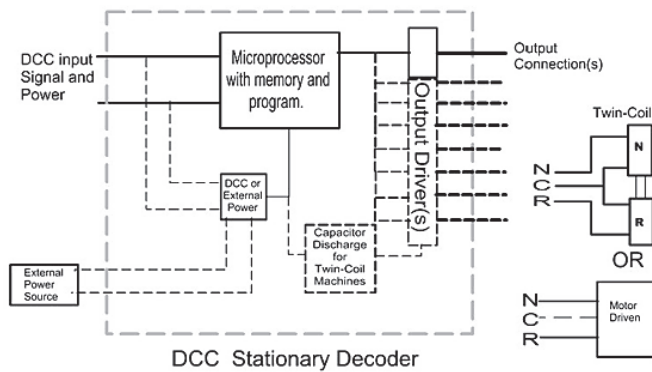

Others call it clear (c) or thrown(t) and + or - has also been used. The drawing shows N for Normal, R for Reverse and C for the common connection.

Numbering and Addressing Decoders

If you need the address of a locomotive just look at the number on the cab. Stationary decoders also have addresses, but these addresses are not as easy to identify. The address range varies with manufacturers. If you are operating turnouts with handheld cabs the turnout address needs to be documented and some how place in a convenient location on the layout as a reference. Numbering is also needed when connecting a computer to the layout for turnout control.

I realized that some type of numbering scheme was needed to identify each turnout with an address. I started with a drawing the layout and then divided it into logical sections. Each section was given a range of ten numbers. This way I know that switches in the Olympia section have numbers from 40 to 49. A drawing was made of each section and the address for each turnout in a section. A section was printed out and put the fascia board near the section.

The addresses available for most stationary decoders run from 1 to 2044. Many DCC system cabs or throttles limit the address range to a maximum of 999. A computer may be needed to use the full address range of 1 to 2044.

SETTING UP DECODERS

Decoder Instructions

The stationary decoder instructions ran from a sheet or two up to over 60 pages. Some were good at explaining how to setup the decoders and some required reading a couple of times. If you are interested in any of the stationary decoders most of the manufacturers have the manuals available on line. Be sure to keep all of the manuals for future reference. I keep all of mine in a three ring binder.

Addressing

Mobile decoders have a default address of 3. Most of the stationary decoders start with an address of 1. Just like the mobile decoders you need to program an address into the decoder. The range of addresses for stationary or accessory decoders is a different address range than mobile decoders. The address range for stationary decoder comes out to 1 to 2044. Some of the decoder setup addresses

in groups of 4. If the first address is 5 then the rest are 6-7-8. Most of the newer decoders allow you to setup any address in their address range. Check the instructions for the decoder for the address range it uses. Since the stationary decoder conform to the NMRA standard/PR any DCC system can be used to operate turnouts. The only limitation is cabs or throttles with no "accessory selection" keys.

Programming

There are different ways to put the decoder into the program mode. The method varies with the manufacturer and the decoder. A few use the program track. Some have a two pin connector on the PC board and move a jumper for the program mode. Others use a wire to set the program mode. Lenz and the new Digitrax decoder have a pushbutton that sets the program mode. Once in a program mode you simply issue an accessory command to the new address, the decoder stores the address. For decoders with more than one output, additional commands may be needed to set the all of the addresses. You may need to also program the type of output or pules length. Take the decoder out of the program mode and the decoder is addressed. One thing lacking in almost all stationary decoder is the read back feature, even on the decoders that use the program track.

In some cases I found it easier to setup a stationary decoder on the bench with a switch machine connected. This way it can be both programed and tested. Once check it can be installed. This is like you using a decoder checker to test out a mobile decoder before it is installed in a locomotive.

Decoder Operation

All stationary decoders start by analyzing the DCC command the same way a mobile decoder checks for its address. If the address matches and there is no error the decoder drives the output. If there are more than one machine to be operated from the same decoder, many of them will store the addresses and operate one at a time in sequence. This allows time for the power to recover between each command. The power for the switch machines can come from either the DCC power/signal or from a separate power source like a plug-in wall wart.

Twin-coil machines need a lot of energy in a single burst. Most use a capacitor discharge unit. It takes time to recharge the capacitor. The NEC Snap-it charges off the DCC input power. The default recharge time is 1.5 seconds and can be programed for up to 4 seconds. The Lenz LS150 has 6 outputs and is powered from a separate power source. When more than one output is selected it sequences thru them at 0.1 seconds each. This can be programed for up to 10 seconds for each step. I used one of the LS150 to drive some low voltage switch motor type machines and set the times to 1 second. I have a macro that switches up to five machines and you can hear them throw one at a time until the sequence is finished.

Powering Stationary Decoders

One common problem when powering stationary decoders is what happens when a turnout is set the wrong way and a locomotive shorts out the rails. If the power for the decoder comes from the rails there is no way to clear the short. There are a couple of solutions for this problem. The best is to use The Hare™ and Tortoise which can line the switch before the short occurs. Another is to wire the power to the stationary decoder separate from the rail supply(booster). If the layout is very large you may need a separate booster for stationary decoders.

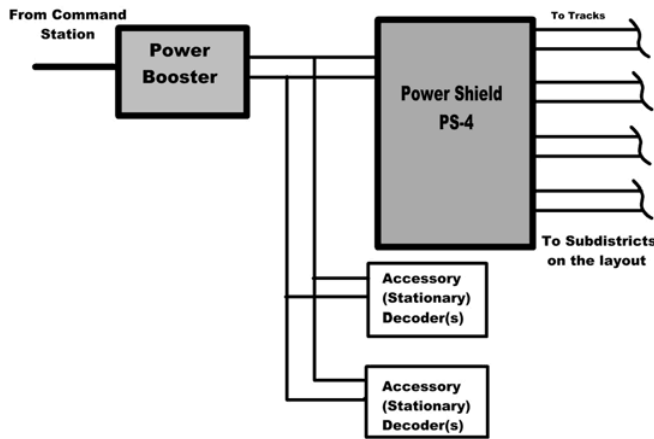

This eliminates problems with shorts affecting the power to the stationary decoders.

Selecting a Stationary Decoder

All stationary decoders use the DCC accessory commands. The type of stationary decoder you use depends on the type of switch machine it will drive and how many outputs are needed. Some need a separate power source. The only plug and play stationary decoder available is the Hare™ that plug directly into the Tortoise.

If a computer is connected you may need feedback of the switch position. The computer can control the switch position and should know the switch's position. But if there is also local switch control of the switch position, it will be different than what is in the computer's memory. This is where there needs to be feedback so the computer can read the actual switch position. The new Hare has a lock feature that allows you to lock in a route to prevent accidental operation. This allows a route to be setup and then locked until a train passes to prevent someone from accidental throwing the switch in front of a train or under it as it passes over the switch.

Larry Maier did many great reviews and tests of stationary decoders. These reviews are still available on our website. The following information was gleaned from Larry Maier's reviews and my personal experience. There are a few of the items where I have question marks. I will make an effort to test these out and update this document. I'm waiting for the DS64 to check it out and then fill in the blanks.

Stationary Decoder and Switch Machine Matrix

Decoder	Digitrax			Lenz		DCC Specialties	NCE			Team Digital
	DS 44	DS 52	DS 64	LS 100	LS 150	The Hare	Switch-it	Snap-it	Switch-Kat	SMD2 SMD8
Switch motor Type A1	Yes	Yes		OK Note1	Poor Note 2	Tortoise	Yes	No	No	Poor
Switch Motor Type A2	No	Yes		No	Yes	No	No	No	No	No
Twin Coil Type B1	No	Yes		Yes	Yes	No	No	Yes	No	Yes
Twin Coil Type B2	No	Yes		Yes	No	No	No	Yes Note 3	No	Yes
Kato or LGB	No	Yes		No	No	No	No	No	Yes	No

Note 1: LA 010 Required for this output.

Note 2: Output not continuous.

Note 3: May need to add capacitor.

Stationary Decoder Comparison

The table below gives a quick comparison of the various features and capabilities of these decoders. These significant differences among the various models. Decoder selection should be based on the intended application. There may be a "Best Choice" for certain functions, but no decoder is "one size fits all".

Decoder	Basic Data							Output Types Available				Programming Modes
	Size (Inches)	MSRP	Number of Outputs	Address Range	Cab Bus Feedback	Plug 'n Play	Separate power Input	Type of Output Note 1	Variable Pulse	Continuous	Alternate Flash	Program Method
Digitrax DS44	1.63 X 0.69	\$39.99	4	1 - 2044	No	No	No	SM	No	Yes	No	Wire
Digitrax DS52	2.0 X 1.75	\$24.99	2	1 - 2044	No	No	No	PR	Fixed Only	Yes	No	Jumper
Digitrax DS54 Note 4	4.0 X 2.7	\$79.99	4	1 - 396	Yes	No	Optional	PR	Yes	Yes	Yes	Jumper
Digitrax DS64 Note 4		\$59.99	4	1-2044	Yes	No	Optional	PR				Push Button
Lenz LS100	3.5 X 3.5	\$79.00	4	1 - 1024	Requires LZ100	No	Optional	PR	Yes	Yes	Yes	Push Button
Lenz LS150	4.7X2.4	\$59.95	6	1-1024	No	No	Yes	PR	Yes	No	No	Push Button
DCC Special The Hare	1.5 X 2.8	\$29.95	1	1-2044	Yes Note 2	Yes	No	SM Note 3	No	Yes	No	Jumper
NCE Switch-It	2.1 X 1.3	\$24.95	2	1 - 2044	Requires AIU-01	No	No	ST	No	Yes	No	Jumper
NCE Snap-It	1.8 X 1.5	\$19.95	1	1-2044	No	No	No	TC	Yes	No	No	Jumper Wire
NCE Switch Kat	2.45 X 1.03	\$24.95	2	1 - 2044	No	No	No	Special	Yes	Yes	No	Jumper Wire
Team Digital SMD2	2.75 X 1.63	\$19.95	2	1 - 2040	Requires SRC8	No	No	PR	Fixed Only	Yes	No	Jumper
Team Digital SMD 8		\$89.95	8	1- 2040	Requires SRC8	No	No	PR	Fixed Only	Yes	No	Jumper

Note 1: SM = Stall Motor TC = Twin Coil PR = Programable for either

Note 2: Feed back is with an Optro-isolator. See Hare Hints and Tips

Note 3: Plugs into a Tortoise. New Hare has programable variable speed.

Note 4: DS64 is new and not release yet. It will replace the DS54.